



S184G Range

Fujian Kwise Generator CO.,LTD

16kW - 32 kW

APPLICATION AND STANDARD

Kwise 4-pole alternators are designed for delivering superior efficiencies in defense, telecoms, airports, hospitals, buildings and oil exploration, industrial and mining continuous or standby power applications.

Alternators are in compliance to the main domestic and international standards and regulations: GB755, BS5000, IEC 60034, VED0530, CSAC22.2 100, NEMA MG-1.22. Alternators are designed, manufactured and marked in ISO 9001 environments.

ELECTRICAL FEATURES

Automatic voltage regulator: KWISE 4 Pole generators are fitted with reliable and performant AVR's, adapted to KWISE excitation systems, and their transistors have a fulfilling perfect voltage regulation function

Short circuit capacity: KWISE propose two choices of excitation systems, depending on the customer needs:

A) SELF-EXCITATION system, without short-circuit capacity.

B) PMG, with a short-circuit capacity of 3 times the nominal current for 10 seconds.

Transient features: Transient voltage dip for rated step load at 0.4 power factor is less than 15%, Recovery time is less than 1.5s.

Parallel operation: All 4 Pole alternators can operate in parallel with other alternators or with the mains, when they are equipped with the appropriate devices (AVR, current transformer...).

Overload acceptance: 4 Pole alternators can be overloaded according to NEMA.

Single Phase operation: 4 Pole alternators SG184 can be reconnected for single phase use. The single phase rating is given in the corresponding generator data sheets. SG184 alternators can be supplied with a dedicated single phase winding. (D51/D61).

Waveform: Total harmonic distortion (THD) at no load or linear load is less than 5% according to IEC. TIF/Telephone influence factor according to NEMA is less than 50.

Frequency: 4 Pole alternators may operate either 50 or 60 Hz. The standard winding (B31, B32) is suitable both for 50 and 60Hz.

Power factor: 4 Pole alternator are designed to operate between 0.8 and 1 power factor. A derating is necessary when power factor is below 0.8 (see derating chart).

MECHANICAL FEATURES

Forms: 4 Pole alternator can be provided in single bearing or double bearing configurations according to customer requirements. Adaptors and coupling discs are available to fit the major engines.

Balancing: All the rotors are dynamically balanced strictly according to ISO1940. The double bearing rotors are dynamically balanced with a half key.

Insulation and protection: 4 Pole alternator are class H insulated. The standard winding protection can accept up to 95% relative humidity and is suitable for indoors marine applications. Specific added coatings can be proposed for particularly harsh environments.

Enclosure: Standard enclosure is IP23.

Direction of rotation: 4 pole alternators SG184 can operate in both directions.

Terminal box and connectors: 4 Pole alternators have a large terminal box which allows easy access for re-connection or to the AVR. Current transformers and other optional modules can be fitted within the box.

Bearings: Sealed for life bearings up to all KWISE 4 Pole alternators.

Overspeed: The maximum overspeed is 2250rpm (1.25 times the 60Hz rated speed).

Mechanical structure: Steel frame. Aluminium, cast iron or steel housings and flanges depending on models.



Fujian Kwise Generator CO.,LTD

4 Pole

KWISE OF CASIC KWISE OF THE WORLD

Common Data

Ambient temp	40°C	Temp rise	125K	Short circuit capacity	/
Altitude	1000m	Voltage regulation	±1%	Cooling method	IC01
Insulation class	Class H	Excitation system	self excitation	Direction of rotation	clockwise
Duty	S1	Winding pitch	2/3	Over speed	2250rpm
Phase	3	Power factor	0.8	Protection	IP23
Pole	4	TIF	<50	Frequency	50/60Hz
AVR	SX460	THF	<2%	THD	<3%

Electrical Data

50Hz/1500RPM		WindingB31/0.8 Power Factor								Winding D51	
Duty/Temp Rise/Ambient T°		Cont./125K/40°C				Standby/150K/40°C				Cont./125K/40°C	
Phase		3 Phase				3Phase				1 Phase	
Voltage	Y	380V	400V	415V	440V	380V	400V	415V	440V	220V/230V/240V	
	Δ	220V	230V	240V		220V	230V	240V		Power Factor	
	YY				220V				220V	0.8	1.0
S184G16C6	KVA	20	20	20	20	22	22	22	22	16	16
	KW	16	16	16	16	17.6	17.6	17.6	17.6	12.8	16
S184G18D7	KVA	22.5	22.5	22.5	22.5	25	25	25	25	18	18
	KW	18	18	18	18	20	20	20	20	14.4	18
S184G20D8	KVA	25	25	25	25	27.5	27.5	27.5	27.5	20	20
	KW	20	20	20	20	22	22	22	22	16	20
S184G22D9	KVA	27.5	27.5	27.5	27.5	31	31	31	31	22	22
	KW	22	22	22	22	24.8	24.8	24.8	24.8	17.6	22
S184G25D10	KVA	31.3	31.3	31.3	31.3	35	35	35	35	25	25
	KW	25	25	25	25	28	28	28	28	20	25
S184G28E11	KVA	35	35	35	35	38.8	38.8	38.8	38.8	35	28
	KW	28	28	28	28	31	31	31	31	28	28
S184G30E12	KVA	37.5	37.5	37.5	37.5	41.3	41.3	41.3	41.3	37.5	30
	KW	30	30	30	30	33	33	33	33	30	30
S184G32E13	KVA	40	40	40	40	43.8	43.8	43.8	43.8	40	32
	KW	32	32	32	32	35	35	35	35	32	32

*Other Voltage:Consult the factory



Fujian Kwise Generator CO.,LTD

4 Pole

KWISE OF CASIC KWISE OF THE WORLD

Electrical Data

60Hz/1800RPM		WindingB32/0.8 Power Factor								Winding D61	
Duty/Temp Rise/Ambient T°		Cont./125K/40°C				Standby/150K/40°C				Cont./125K/40°C	
Phase		3 Phase				3Phase				1 Phase	
Voltage	Y	416V	440V	460V	480V	416V	440V	460V	480V	220V/230V/240V	
	Δ	240V				240V				Power Factor	
	YY	208V	220V	230V	240V	208V	220V	230V	240V	0.8	1.0
S184G16C6	KVA	24	24	24	24	26.4	26.4	26.4	26.4	19.2	19.2
	KW	19.2	19.2	19.2	19.2	21.1	21.1	21.1	21.1	15.4	19.2
S184G18D7	KVA	27	27	27	27	30	30	30	30	21.6	21.6
	KW	21.6	21.6	21.6	21.6	24	24	24	24	17.3	21.6
S184G20D8	KVA	30	30	30	30	33	33	33	33	24	24
	KW	24	24	24	24	26.4	26.4	26.4	26.4	19.2	24
S184G22D9	KVA	33	33	33	33	37.2	37.2	37.2	37.2	26.4	26.4
	KW	26.4	26.4	26.4	26.4	29	29	29	29	21.1	26.4
S184G25D10	KVA	37.5	37.5	37.5	37.5	42	42	42	42	30	30
	KW	30	30	30	30	33.6	33.6	33.6	33.6	24	30
S184G28E11	KVA	42	42	42	42	46.5	46.5	46.5	46.5	33.6	33.6
	KW	33.6	33.6	33.6	33.6	37.2	37.2	37.2	37.2	26.9	33.6
S184G30E12	KVA	45	45	45	45	49.5	49.5	49.5	49.5	36	36
	KW	36	36	36	36	39.6	39.6	39.6	39.6	28.8	36
S184G32E13	KVA	48	48	48	48	52.5	52.5	52.5	52.5	38.4	38.4
	KW	38.4	38.4	38.4	38.4	42	42	42	42	30.7	38.4

*Other Voltage:Consult the factory

Inertia & Efficiency

Model	S184G	16C6	18D7	20D8	22D9	25D10	28E11	30E12	32E13
Inertia(SB).J	kgm^2	0.147	0.165	0.182	0.201	0.231	0.263	0.284	0.290
Efficiency(100%Load)	%	83.2	83.9	84.6	85.5	86	86.6	87	87.2



4 Pole

Fujian Kwise Generator CO.,LTD

KWise OF CASIC KWise OF THE WORLD

Reactance-time constant(s)

50Hz @ 400V	S184G	16C6	18D7	20D8	22D9	25D10	28E11	30E12	32E13
Short-circuit ratio	Kcc	0.585	0.592	0.599	0.606	0.641	0.513	0.500	0.488
Direct-axis synchro. reactance unsaturated	Xd	1.710	1.690	1.670	1.650	1.560	1.949	2.000	2.051
Direct-axis transient reactance saturated	X'd	0.180	0.175	0.170	0.165	0.150	0.148	0.152	0.156
Direct-axis subtransient reactance saturated	X''d	0.122	0.120	0.117	0.113	0.110	0.081	0.083	0.085
Quadrature-axis synchro. Reactance unsaturated	Xq	0.845	0.840	0.835	0.830	0.780	0.944	0.967	0.990
Quadrature-axis subtransient reactance saturated	X''q	0.190	0.190	0.191	0.191	0.170	0.165	0.169	0.173
Negative sequence reactance saturated	X2	0.165	0.160	0.155	0.150	0.140	0.124	0.127	0.130
Zero sequence reactance	X0	0.074	0.073	0.073	0.072	0.067	0.028	0.030	0.032
Short-circuit transient time constant	T'd	0.019s	0.020s	0.021s	0.022s	0.024s	0.023s	0.024s	0.025s
Subtransient time constant	T''d	0.0045s	0.005s	0.0055s	0.0055s	0.006s	0.014s	0.015s	0.016s
No-load transient time constant	T'do	0.35s	0.4s	0.43s	0.45s	0.55s	0.55s	0.57s	0.59s
Armature time constant	Ta	0.0055s	0.006s	0.0063	0.0065s	0.007s	0.0103s	0.01s	0.0105s

60Hz @ 440V	S184G	16C6	18D7	20D8	22D9	25D10	28E11	30E12	32E13
Short-circuit ratio	Kcc	0.455	0.466	0.477	0.489	0.539	0.413	0.420	0.435
Direct-axis synchro. reactance unsaturated	Xd	2.199	2.148	2.098	2.047	1.857	2.423	2.380	2.297
Direct-axis transient reactance saturated	X'd	0.226	0.217	0.208	0.199	0.190	0.183	0.181	0.175
Direct-axis subtransient reactance saturated	X''d	0.136	0.137	0.139	0.140	0.119	0.103	0.099	0.095
Quadrature-axis synchro. Reactance unsaturated	Xq	1.080	1.063	1.046	1.029	0.916	1.162	1.151	1.109
Quadrature-axis subtransient reactance saturated	X''q	0.243	0.240	0.237	0.234	0.202	0.208	0.201	0.194
Negative sequence reactance saturated	X2	0.198	0.194	0.191	0.187	0.179	0.157	0.151	0.145
Zero sequence reactance	X0	0.095	0.093	0.091	0.089	0.080	0.036	0.036	0.036
Short-circuit transient time constant	T'd	0.018s	0.02s	0.021s	0.022s	0.024s	0.023s	0.024s	0.025s
Subtransient time constant	T''d	0.0045s	0.005s	0.005s	0.0055s	0.006s	0.014s	0.015s	0.016s
No-load transient time constant	T'do	0.35s	0.40s	0.40s	0.45s	0.55s	0.55s	0.57s	0.59s
Armature time constant	Ta	0.005s	0.006s	0.006s	0.0065s	0.007s	0.0103s	0.010s	0.0105s

Outline Drawing (Single Bearing)

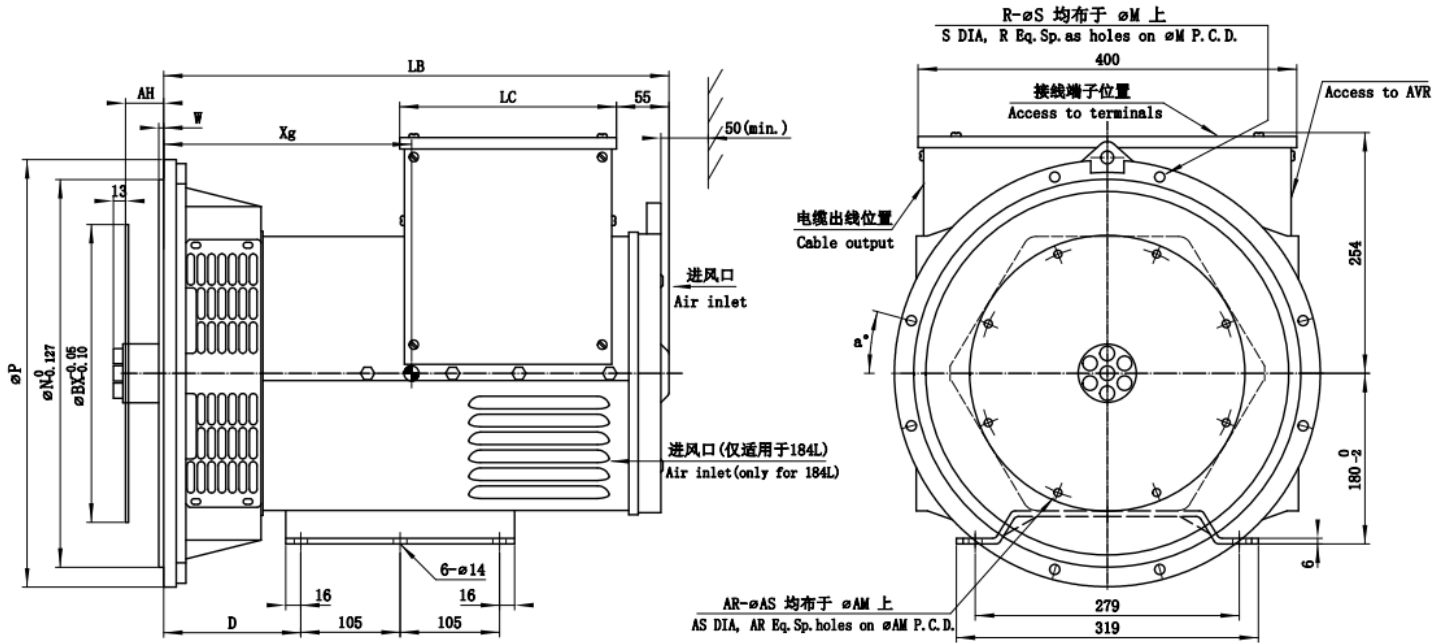

Dimensions(mm)							
Model	LB			LC	*Xg	Net W.	Packing
	SAE2	SAE3	SAE4&5				
	mm	mm	mm				
S184G16C6	481	454	442	229	202	112	634*504*572
S184G18D7	561	534	522	229	210	117	704*504*572
S184G20D8	561	534	522	229	232	129	704*504*572
S184G22D9	561	534	522	229	242	137	704*504*572
S184G25D10	561	534	522	229	262	153	704*504*572
S184G28E11	621	594	582	274	270	175	754*504*572
S184G30E12	621	594	582	274	276	195	754*504*572
S184G32E13	621	594	582	274	287	215	754*504*572

Flange (mm)								Coupling Discs (mm)				
S.A.E	P	N	M	R-øS	W	D	a°	S.A.E	BX	AM	AR-øAS	AH
#2	490	447.675	466.725	12-ø11	6	172	15°	#6.5	215.9	200.025	6-ø9	30.2
#3	451	409.575	428.625	8-ø11	6	145	15°	#7.5	241.3	222.25	8-ø9	30.2
#4	402	361.95	381	8-ø11	5	133	15°	#8	263.525	244.475	6-ø11	62
#5	356	314.325	333.375	8-ø11	5	133	22.5°	#10	314.325	295.275	8-ø11	53.8
								#11.5	352.425	333.375	8-ø11	39.6

Outline Drawing (Double Bearing)

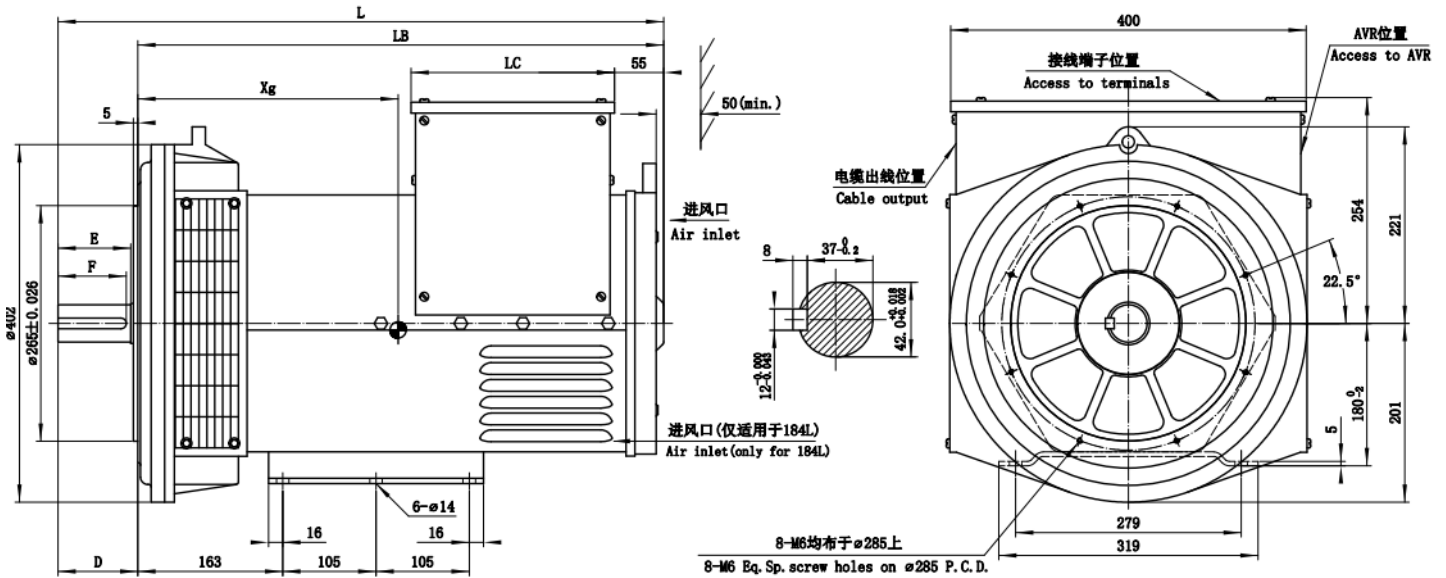

Dimensions(mm)

Model	L	LB	LC	D	E	F	*Xg	Net W.	Packing
	mm	mm	mm	mm	mm	mm	mm	kg	L x W x H(mm)
S184G16C6	562	472	229	90	82	77	233	117	704*504*572
S184G18D7	642	552	229	90	82	77	247	128	754*504*572
S184G20D8	642	552	229	90	82	77	263	143	754*504*572
S184G22D9	642	552	229	90	82	77	273	151	754*504*572
S184G25D10	642	552	229	90	82	77	293	167	754*504*572
S184G28E11	702	612	274	118	110	100	307	189	794*544*857
S184G30E12	702	612	274	118	110	100	313	209	794*544*857
S184G32E13	702	612	274	118	110	100	320	229	794*544*857