



Fujian Kwise Generator CO.,LTD

L224A Range

32kW - 75 kW

APPLICATION AND STANDARD

Kwise 4-pole alternators are designed for delivering superior efficiencies in defense, telecoms, airports, hospitals, buildings and oil exploration, industrial and mining continuous or standby power applications.

Alternators are in compliance to the main domestic and international standards and regulations: GB755, BS5000, IEC 60034, VED0530, CSAC22.2 100, NEMA MG-1.22. Alternators are designed, manufactured and marked in ISO 9001 environments.

ELECTRICAL FEATURES

Automatic voltage regulator: KWISE 4 Pole generators are fitted with reliable and performant AVR's, adapted to KWISE excitation systems, and their transistors have a fulfilling perfect voltage regulation function

Short circuit capacity: KWISE propose two choices of excitation systems, depending on the customer needs:

A) SELF-EXCITATION system, without short-circuit capacity.

B) PMG, with a short-circuit capacity of 3 times the nominal current for 10 seconds.

Transient features: Transient voltage dip for rated step load at 0.4 power factor is less than 15%, Recovery time is less than 1.5s.

Parallel operation: All 4 Pole alternators can operate in parallel with other alternators or with the mains, when they are equipped with the appropriate devices (AVR, current transformer...).

Overload acceptance: 4 Pole alternators can be overloaded according to NEMA.

Single Phase operation: 4 Pole alternators LA224 can be reconnected for single phase use. LA224 alternators can be supplied with a dedicated single phase winding. (D51/D61).

Waveform: Total harmonic distortion (THD) at no load or linear load is less than 5% according to IEC. TIF/Telephone influence factor according to NEMA is less than 50.

Frequency: 4 Pole alternators may operate either 50 or 60 Hz. The standard winding (B31, B32) is suitable both for 50 and 60Hz.

Power factor: 4 Pole alternators are designed to operate between 0.8 and 1 power factor. A derating is necessary when power factor is below 0.8 (see derating chart).

MECHANICAL FEATURES

Forms: 4 Pole alternator can be provided in single bearing or double bearing configurations according to customer requirements. Adaptors and coupling discs are available to fit the major engines.

Balancing: All the rotors are dynamically balanced strictly according to ISO1940. The double bearing rotors are dynamically balanced with a half key.

Insulation and protection: 4 Pole alternators are class H insulated. The standard winding protection can accept up to 95% relative humidity and is suitable for indoors marine applications. Specific added coatings can be proposed for particularly harsh environments.

Enclosure: Standard enclosure is IP23.

Direction of rotation: 4 pole alternators LA224 can operate in both directions.

Terminal box and connectors: 4 Pole alternators have a large terminal box which allows easy access for re-connection or to the AVR. Current transformers and other optional modules can be fitted within the box.

Bearings: Sealed for life bearings up to all KWISE 4 Pole alternators.

Overspeed: The maximum overspeed is 2250rpm (1.25 times the 60Hz rated speed).

Mechanical structure: Steel frame. Aluminium, cast iron or steel housings and flanges depending on models.



Fujian Kwise Generator CO.,LTD

4 Pole

KWISE OF CASIC KWISE OF THE WORLD

Common Data

Ambient temp	40°C	Temp rise	125K	Short circuit capacity	/
Altitude	1000m	Voltage regulation	±1%	Cooling method	IC01
Insulation class	Class H	Excitation system	self excitation	Direction of rotation	clockwise
Duty	S1	Winding pitch	2/3	Over speed	2250rpm
Phase	3	Power factor	0.8	Protection	IP23
Pole	4	TIF	<50	Frequency	50/60Hz
AVR	SX460	THF	<2%	THD	<3%

Electrical Data

50Hz/1500RPM		WindingB31/0.8 Power Factor							
Duty/Temp Rise/Ambient T°		Cont./125K/40°C				Standby/150K/40°C			
Phase		3 Phase				3Phase			
Voltage	Y	380V	400V	415V	440V	380V	400V	415V	440V
	Δ	220V	230V	240V		220V	230V	240V	
	YY				220V				220V
L224A32B1	KVA	40	40	40	40	44	44	44	44
	KW	32	32	32	32	35	35	35	35
L224A34B2	KVA	43	43	43	40	47	47	47	47
	KW	34	34	34	34	37	37	37	37
L224A40B3	KVA	50	50	50	48	55	55	55	53
	KW	40	40	40	38	44	44	44	42
L224A45B4	KVA	56	56	56	54	62	62	62	59
	KW	45	45	45	43	50	50	50	47
L224A50C5	KVA	63	63	63	60	69	69	69	66
	KW	50	50	50	48	55	55	55	53
L224A54C6	KVA	68	68	68	65	74	74	74	72
	KW	54	54	54	52	59	59	59	58
L224A58C7	KVA	73	73	73	70	81	81	81	79
	KW	58	58	58	56	65	65	65	63
L224A64D8	KVA	80	80	80	76	88	88	88	84
	KW	64	64	64	61	70	70	70	67
L224A68D9	KVA	85	85	85	79	94	94	94	89
	KW	68	68	68	63.2	75	75	75	71
L224A75D10	KVA	94	94	94	86	103	103	103	96
	KW	75	75	75	69	83	83	83	77

*Other Voltage:Consult the factory



Fujian Kwise Generator CO.,LTD

4 Pole

KWISE OF CASIC KWISE OF THE WORLD

Electrical Data

60Hz/1800RPM		WindingB32/0.8 Power Factor							
Duty/Temp Rise/Ambient T°		Cont./125K/40°C				Standby/150K/40°C			
Phase		3 Phase				3Phase			
Voltage	Y	416V	440V	460V	480V	416V	440V	460V	480V
	Δ	240V				240V			
	YY	208V	220V	230V	240V	208V	220V	230V	240V
L224A32B1	KVA	48	48	48	48	53	53	53	53
	KW	38	38	38	38	42	42	42	42
L224A34B2	KVA	51	51	51	51	56	56	56	56
	KW	41	41	41	41	45	45	45	45
L224A40B3	KVA	60	60	60	60	66	66	66	66
	KW	48	48	48	48	53	53	53	53
L224A45B4	KVA	68	68	68	68	74	74	74	74
	KW	54	54	54	54	59	59	59	59
L224A50C5	KVA	75	75	75	75	83	83	83	83
	KW	60	60	60	60	66	66	66	66
L224A54C6	KVA	81	81	81	81	89	89	89	89
	KW	65	65	65	65	71	71	71	71
L224A58C7	KVA	87	87	87	87	96	96	96	96
	KW	70	70	70	70	77	77	77	77
L224A64D8	KVA	96	96	96	96	106	106	106	106
	KW	77	77	77	77	85	85	85	85
L224A68D9	KVA	102	102	102	102	112	112	112	112
	KW	82	82	82	82	90	90	90	90
L224A75D10	KVA	113	113	113	113	124	124	124	124
	KW	90	90	90	90	99	99	99	99

*Other Voltage:Consult the factory

Inertia & Efficiency

Model	L224A	32B1	34B2	40B3	45B4	50C5	54C6	58C7	64D8	68D9	75D10
Inertia(SB).J	kgm^2	0.374	0.419	0.443	0.525	0.547	0.592	0.637	0.704	0.749	0.792
Efficiency(100%Load)	%	87.4	88.1	88.9	89.1	89.5	89.6	90.7	90.8	90.9	90.9



Fujian Kwise Generator CO.,LTD

4 Pole

KWISE OF CASIC KWISE OF THE WORLD

Reactance-time constant(s)

50Hz @ 400V	L224A	32B1	34B2	40B3	45B4	50C5	54C6	58C7	64D8	68D9	75D10
Short-circuit ratio	Kcc	0.439	0.457	0.476	0.461	0.446	0.464	0.483	0.468	0.455	0.442
Direct-axis synchro. reactance unsaturated	Xd	2.280	2.190	2.100	2.170	2.240	2.155	2.070	2.135	2.200	2.265
Direct-axis transient reactance saturated	X'd	0.180	0.170	0.160	0.165	0.170	0.165	0.160	0.165	0.170	0.175
Direct-axis subtransient reactance saturated	X''d	0.110	0.110	0.110	0.115	0.120	0.115	0.110	0.115	0.120	0.125
Quadrature-axis synchro. Reactance unsaturated	Xq	1.050	1.010	0.970	0.995	1.020	0.985	0.950	0.980	1.010	1.040
Quadrature-axis subtransient reactance saturated	X''q	0.150	0.140	0.130	0.130	0.130	0.135	0.140	0.145	0.150	0.155
Negative sequence reactance saturated	X2	0.140	0.130	0.120	0.120	0.120	0.125	0.130	0.135	0.140	0.145
Zero sequence reactance	X0	0.100	0.090	0.080	0.090	0.100	0.100	0.100	0.100	0.100	0.100
Short-circuit transient time constant	T'd	0.023s	0.025s	0.027s	0.027s	0.028s	0.027s	0.030s	0.031s	0.032s	0.032s
Subtransient time constant	T''d	0.006s	0.006s	0.006s	0.006s	0.007s	0.008s	0.008s	0.008s	0.008s	0.008s
No-load transient time constant	T'do	0.60s	0.65s	0.70s	0.70s	0.70s	0.65s	0.70s	0.75s	0.75s	0.80s
Armature time constant	Ta	0.0045s	0.005s	0.0055s	0.006s	0.006s	0.0065s	0.0065s	0.007s	0.007s	0.0075s

60Hz @ 440V	L224A	32B1	34B2	40B3	45B4	50C5	54C6	58C7	64D8	68D9	75D10
Short-circuit ratio	Kcc	0.351	0.352	0.353	0.357	0.360	0.390	0.426	0.415	0.405	0.395
Direct-axis synchro. reactance unsaturated	Xd	0.850	2.840	2.830	2.805	2.780	2.565	2.350	2.410	2.470	2.530
Direct-axis transient reactance saturated	X'd	0.220	0.210	0.200	0.200	0.200	0.200	0.200	0.195	0.190	0.185
Direct-axis subtransient reactance saturated	X''d	0.140	0.140	0.140	0.140	0.140	0.135	0.130	0.130	0.130	0.130
Quadrature-axis synchro. Reactance unsaturated	Xq	1.320	1.310	1.300	1.290	1.280	1.180	1.080	1.105	1.130	1.155
Quadrature-axis subtransient reactance saturated	X''q	0.135	0.130	0.130	0.130	0.130	0.125	0.120	0.130	0.140	0.150
Negative sequence reactance saturated	X2	0.110	0.120	0.130	0.130	0.130	0.125	0.120	0.130	0.140	0.150
Zero sequence reactance	X0	0.070	0.075	0.080	0.080	0.080	0.085	0.090	0.095	0.100	0.105
Short-circuit transient time constant	T'd	0.023s	0.025s	0.027s	0.027s	0.028s	0.027s	0.030s	0.031s	0.032s	0.032s
Subtransient time constant	T''d	0.006s	0.006s	0.006s	0.006s	0.007s	0.008s	0.008s	0.008s	0.008s	0.008s
No-load transient time constant	T'do	0.60s	0.65s	0.70s	0.70s	0.70s	0.65s	0.70s	0.75s	0.75s	0.80s
Armature time constant	Ta	0.0045s	0.005s	0.0055s	0.006s	0.006s	0.0065s	0.0065s	0.007s	0.007s	0.0075s

Outline Drawing (Single Bearing)

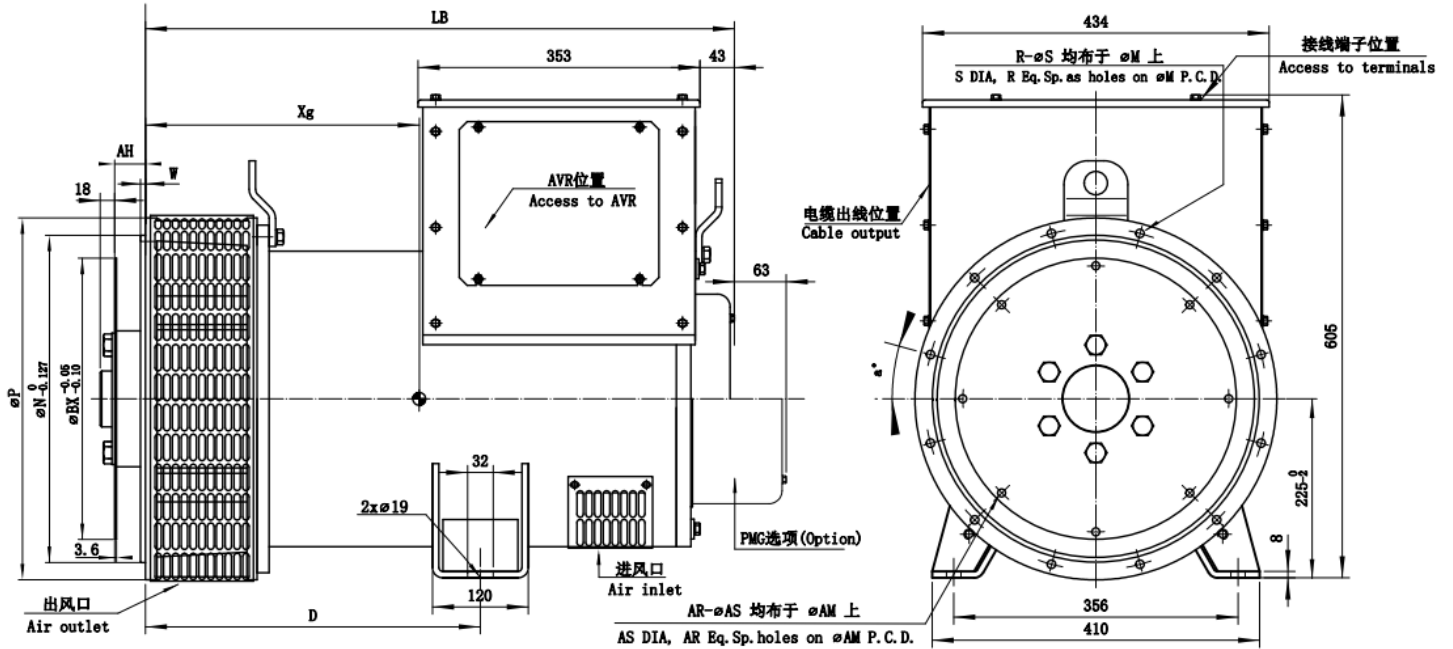

Dimensions(mm)					
Model	LB		*Xg	Net W.	Packing
	SAE1	SAE2&3&4			
	mm	mm	mm	kg	L x W x H(mm)
L224A32B1	661.3	647	302	222	794*544*857
L224A34B2	661.3	647	311	223	794*544*857
L224A40B3	661.3	647	321	236	794*544*857
L224A45B4	661.3	647	332	247	794*544*857
L224A50C5	751.3	737	340	270	894*544*857
L224A54C6	751.3	737	343	282	894*544*857
L224A58C7	751.3	737	346	292	894*544*857
L224A64D8	796.3	782	354	315	934*544*857
L224A68D9	796.3	782	361	328	934*544*857
L224A75D10	796.3	782	371	340	934*544*857

Flange (mm)								Coupling Discs (mm)				
S.A.E	P	N	M	R-øS	W	D	a°	S.A.E	BX	AM	AR-øAS	AH
#1	533	511.175	530.225	12-ø12	6	346.8	15°	#7.5	241.3	222.25	8-ø9	30.2
#2	490	447.675	466.725	12-ø12	5	332.5	15°	#8	263.525	244.475	6-ø11	62
#3	451	409.575	428.625	12-ø12	5	332.5	15°	#10	314.3	295.275	8-ø11	53.8
#4	402	361.95	381	12-ø12	5	332.5	15°	#11.5	352.4	333.38	8-ø11	39.6
								#14	466.725	438.15	8-ø14	25.4

Outline Drawing (Double Bearing)

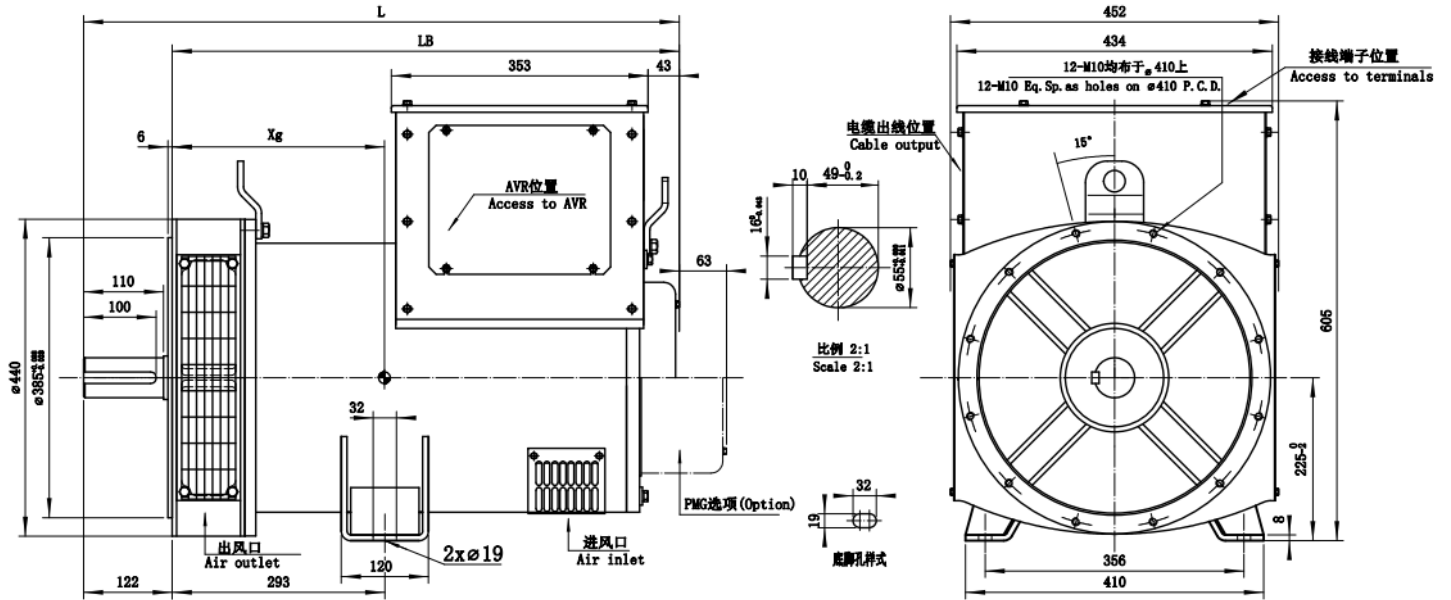

Dimensions(mm)					
Model	L	LB	*Xg	Net W.	Packing
	mm	mm	mm	kg	L x W x H(mm)
L224A32B1	729	607	263	232	894*544*857
L224A34B2	729	607	263	238	894*544*857
L224A40B3	729	607	273	256	894*544*857
L224A45B4	729	607	273	265	894*544*857
L224A50C5	819	697	292	290	934*544*857
L224A54C6	819	697	292	304	934*544*857
L224A58C7	819	697	298	302	934*544*857
L224A64D8	864	742	306	325	1024*624*947
L224A68D9	864	742	313	338	1024*624*947
L224A75D10	864	742	323	350	1024*624*947