



Fujian Kwise Generator CO.,LTD

L164A Range

6.5kW - 16 kW

APPLICATION AND STANDARD

Kwise 4-pole alternators are designed for delivering superior efficiencies in defense, telecoms, airports, hospitals, buildings and oil exploration, industrial and mining continuous or standby power applications.

Alternators are in compliance to the main domestic and international standards and regulations: GB755, BS5000, IEC 60034, VED0530, CSAC22.2 100, NEMA MG-1.22. Alternators are designed, manufactured and marked in ISO 9001 environments.

ELECTRICAL FEATURES

Automatic voltage regulator: KWISE 4 Pole generators are fitted with reliable and performant AVR's, adapted to KWISE excitation systems, and their transistors have a fulfilling perfect voltage regulation function

Short circuit capacity: KWISE propose two choices of excitation systems, depending on the customer needs:

A) SELF-EXCITATION system, without short-circuit capacity.

B) PMG, with a short-circuit capacity of 3 times the nominal current for 10 seconds.

Transient features: Transient voltage dip for rated step load at 0.4 power factor is less than 15%, Recovery time is less than 1.5s.

Parallel operation: All 4 Pole alternators can operate in parallel with other alternators or with the mains, when they are equipped with the appropriate devices (AVR, current transformer...).

Overload acceptance: 4 Pole alternators can be overloaded according to NEMA.

Single Phase operation: 4 Pole alternators LA164 can be reconnected for single phase use. The single phase rating is given in the corresponding generator data sheets. LA164 alternators can be supplied with a dedicated single phase winding. (D51/D61).

Waveform: Total harmonic distortion (THD) at no load or linear load is less than 5% according to IEC. TIF/Telephone influence factor according to NEMA is less than 50.

Frequency: 4 Pole alternators may operate either 50 or 60 Hz. The standard winding (B31, B32) is suitable both for 50 and 60Hz.

Power factor: 4 Pole alternator are designed to operate between 0.8 and 1 power factor. A derating is necessary when power factor is below 0.8 (see derating chart).

MECHANICAL FEATURES

Forms: 4 Pole alternator can be provided in single bearing or double bearing configurations according to customer requirements. Adaptors and coupling discs are available to fit the major engines.

Balancing: All the rotors are dynamically balanced strictly according to ISO1940. The double bearing rotors are dynamically balanced with a half key.

Insulation and protection: 4 Pole alternator are class H insulated. The standard winding protection can accept up to 95% relative humidity and is suitable for indoors marine applications. Specific added coatings can be proposed for particularly harsh environments.

Enclosure: Standard enclosure is IP23.

Direction of rotation: 4 pole alternators LA164 can operate in both directions.

Terminal box and connectors: 4 Pole alternators have a large terminal box which allows easy access for re-connection or to the AVR. Current transformers and other optional modules can be fitted within the box.

Bearings: Sealed for life bearings up to all KWISE 4 Pole alternators.

Overspeed: The maximum overspeed is 2250rpm (1.25 times the 60Hz rated speed).

Mechanical structure: Steel frame. Aluminium, cast iron or steel housings and flanges depending on models.



Fujian Kwise Generator CO.,LTD

4 Pole

KWISE OF CASIC KWISE OF THE WORLD

Common Data

Ambient temp	40°C	Temp rise	125K	Short circuit capacity	/
Altitude	1000m	Voltage regulation	±1%	Cooling method	IC01
Insulation class	Class H	Excitation system	self excitation	Direction of rotation	clockwise
Duty	S1	Winding pitch	2/3	Over speed	2250rpm
Phase	3	Power factor	0.8	Protection	IP23
Pole	4	TIF	<50	Frequency	50/60Hz
AVR	SX460	THF	<2%	THD	<3%

Electrical Data

50Hz/1500RPM		WindingB31/0.8 Power Factor								Winding D51	
Duty/Temp Rise/Ambient T°		Cont./125K/40°C				Standby/150K/40°C				Cont./125K/40°C	
Phase		3 Phase				3Phase				1 Phase	
Voltage	Y	380V	400V	415V	440V	380V	400V	415V	440V	220V/230V/240V	
	Δ	220V	230V	240V		220V	230V	240V		Power Factor	
	YY				220V				220V	0.8	1.0
L164A65B1	KVA	8.1	8.1	8.1	8.1	8.8	8.8	8.8	8.8	6.5	6.5
	KW	6.5	6.5	6.5	6.5	7	7	7	7	5.1	6.5
L164A88B2	KVA	11	11	11	11	11.9	11.9	11.9	11.9	8.8	8.8
	KW	8.8	8.8	8.8	8.8	9.5	9.5	9.5	9.5	7	8.8
L164A108B3	KVA	13.5	13.5	13.5	13.5	14.8	14.8	14.8	14.8	10.8	10.8
	KW	10.8	10.8	10.8	10.8	11.8	11.8	11.8	11.8	8.6	10.8
L164A128C4	KVA	16	16	16	16	17.5	17.5	17.5	17.5	12.8	12.8
	KW	12.8	12.8	12.8	12.8	14	14	14	14	10.2	12.8
L164A14C5	KVA	17.5	17.5	17.5	17.5	19.3	19.3	19.3	19.3	14	14
	KW	14	14	14	14	15.4	15.4	15.4	15.4	11.2	14
L164A16C6	KVA	20	20	20	20	22	22	22	22	16	16
	KW	16	16	16	16	17.6	17.6	17.6	17.6	12.8	16

*Other Voltage:Consult the factory



Fujian Kwise Generator CO.,LTD

4 Pole

KWISE OF CASIC KWISE OF THE WORLD

Electrical Data

60Hz/1800RPM		WindingB32/0.8 Power Factor								Winding D61	
Duty/Temp Rise/Ambient T°		Cont./125K/40°C				Standby/150K/40°C				Cont./125K/40°C	
Phase		3 Phase				3Phase				1 Phase	
Voltage	Y	416V	440V	460V	480V	416V	440V	460V	480V	220V/230V/240V	
	Δ	240V				240V				Power Factor	
	YY	208V	220V	230V	240V	208V	220V	230V	240V	0.8	1.0
L164A65B1	KVA	9.8	9.8	9.8	9.8	10.5	10.5	10.5	10.5	7.8	7.8
	KW	7.8	7.8	7.8	7.8	8.4	8.4	8.4	8.4	6.2	7.8
L164A88B2	KVA	13.2	13.2	13.2	13.2	14.3	14.3	14.3	14.3	10.6	10.6
	KW	10.6	10.6	10.6	10.6	11.4	11.4	11.4	11.4	8.5	10.6
L164A108B3	KVA	16.2	16.2	16.2	16.2	17.7	17.7	17.7	17.7	13	13
	KW	13	13	13	13	14.2	14.2	14.2	14.2	10.4	13
L164A128C4	KVA	19.2	19.2	19.2	19.2	21	21	21	21	15.4	15.4
	KW	15.4	15.4	15.4	15.4	16.8	16.8	16.8	16.8	12.3	15.4
L164A14C5	KVA	21	21	21	21	23.1	23.1	23.1	23.1	16.8	16.8
	KW	16.8	16.8	16.8	16.8	18.5	18.5	18.5	18.5	13.4	16.8
L164A16C6	KVA	24	24	24	24	26.4	26.4	26.4	26.4	19.2	19.2
	KW	19.2	19.2	19.2	19.2	21.1	21.1	21.1	21.1	15.4	19.2

*Other Voltage:Consult the factory

Inertia & Efficiency

Model	L164A	65B1	88B2	108B3	128C4	14C5	16C6
Inertia(SB).J	kgm^2	0.097	0.108	0.123	0.134	0.142	0.147
Efficiency(100%Load)	%	78.8	79.9	80.8	81.6	82.3	83.2



Fujian Kwise Generator CO.,LTD

4 Pole

KWise OF CASIC KWise OF THE WORLD

Reactance-time constant(s)

50Hz @ 400V	L164A	65B1	88B2	108B3	128C4	14C5	16C6
Short-circuit ratio	Kcc	0.556	0.563	0.570	0.577	0.584	0.585
Direct-axis synchro. reactance unsaturated	Xd	1.8	1.777	1.754	1.734	1.711	1.710
Direct-axis transient reactance saturated	X'd	0.184	0.181	0.179	0.177	0.174	0.180
Direct-axis subtransient reactance saturated	X''d	0.115	0.113	0.112	0.111	0.109	0.122
Quadrature-axis synchro. Reactance unsaturated	Xq	0.895	0.883	0.872	0.861	0.849	0.845
Quadrature-axis subtransient reactance saturated	X''q	0.207	0.203	0.201	0.199	0.196	0.190
Negative sequence reactance saturated	X2	0.172	0.17	0.168	0.166	0.164	0.165
Zero sequence reactance	X0	0.078	0.077	0.076	0.075	0.074	0.074
Short-circuit transient time constant	T'd	0.012 s	0.014 s	0.016 s	0.018 s	0.020 s	0.019s
Subtransient time constant	T''d	0.003 s	0.0035 s	0.004 s	0.0045 s	0.005 s	0.0045s
No-load transient time constant	T'do	0.2 s	0.25 s	0.3 s	0.35 s	0.4 s	0.35s
Armature time constant	Ta	0.004 s	0.0045 s	0.005 s	0.0055 s	0.006 s	0.0055s

60Hz @ 440V	L164A	65B1	88B2	108B3	128C4	14C5	16C6
Short-circuit ratio	Kcc	0.445	0.452	0.460	0.465	0.473	0.455
Direct-axis synchro. reactance unsaturated	Xd	2.248	2.211	2.174	2.149	2.112	2.199
Direct-axis transient reactance saturated	X'd	0.23	0.225	0.223	0.219	0.2155	0.226
Direct-axis subtransient reactance saturated	X''d	0.144	0.14	0.139	0.138	0.1355	0.136
Quadrature-axis synchro. Reactance unsaturated	Xq	1.117	1.098	1.081	1.068	1.05	1.080
Quadrature-axis subtransient reactance saturated	X''q	0.258	0.252	0.249	0.246	0.2415	0.243
Negative sequence reactance saturated	X2	0.215	0.212	0.208	0.206	0.2025	0.198
Zero sequence reactance	X0	0.098	0.096	0.094	0.093	0.091	0.095
Short-circuit transient time constant	T'd	0.012 s	0.014 s	0.016 s	0.018 s	0.020 s	0.018s
Subtransient time constant	T''d	0.003 s	0.0035 s	0.004 s	0.0045 s	0.005 s	0.0045s
No-load transient time constant	T'do	0.2 s	0.25 s	0.3 s	0.35 s	0.4 s	0.35s
Armature time constant	Ta	0.004 s	0.0045 s	0.005 s	0.0055 s	0.006 s	0.005s

Outline Drawing (Single Bearing)

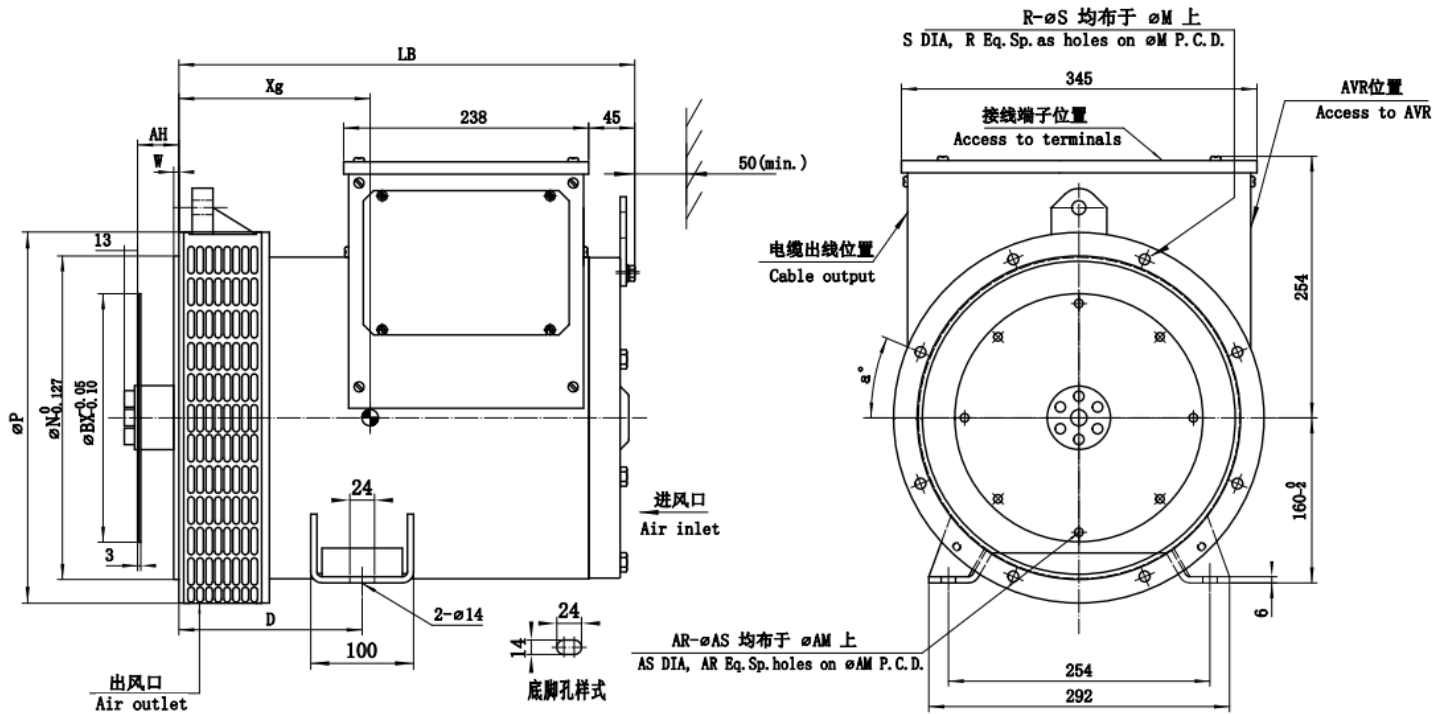

Dimensions (mm)

Model	LB		*Xg	Net W.	Packing
	SAE3	SAE4&5			
	mm	mm			
L164A65B1	409	397	152	78	574*504*572
L164A88B2	409	397	162	84	574*504*572
L164A108B3	409	397	172	93	574*504*572
L164A128C4	454	442	186	101	634*504*572
L164A14C5	454	442	194	105	634*504*572
L164A16C6	455	443	202	116	634*504*572

Flange (mm)						
S.A.E	P	N	M	R-øS	W	a°
#3	451	409.575	428.625	12-ø12	5	15°
#4	402	361.95	381	12-ø12	5	15°
#5	356	314.325	333.375	8-ø12	5	22.5°

Coupling Discs (mm)				
S.A.E	BX	AM	AR-øAS	AH
#6.5	215.9	200.025	6-ø9	30.2
#7.5	241.3	222.25	8-ø9	30.2
#8	263.525	244.475	6-ø11	62
#10	314.325	295.3	8-ø11	53.8
#11.5	352.425	333.38	8-ø11	39.6

Outline Drawing (Double Bearing)

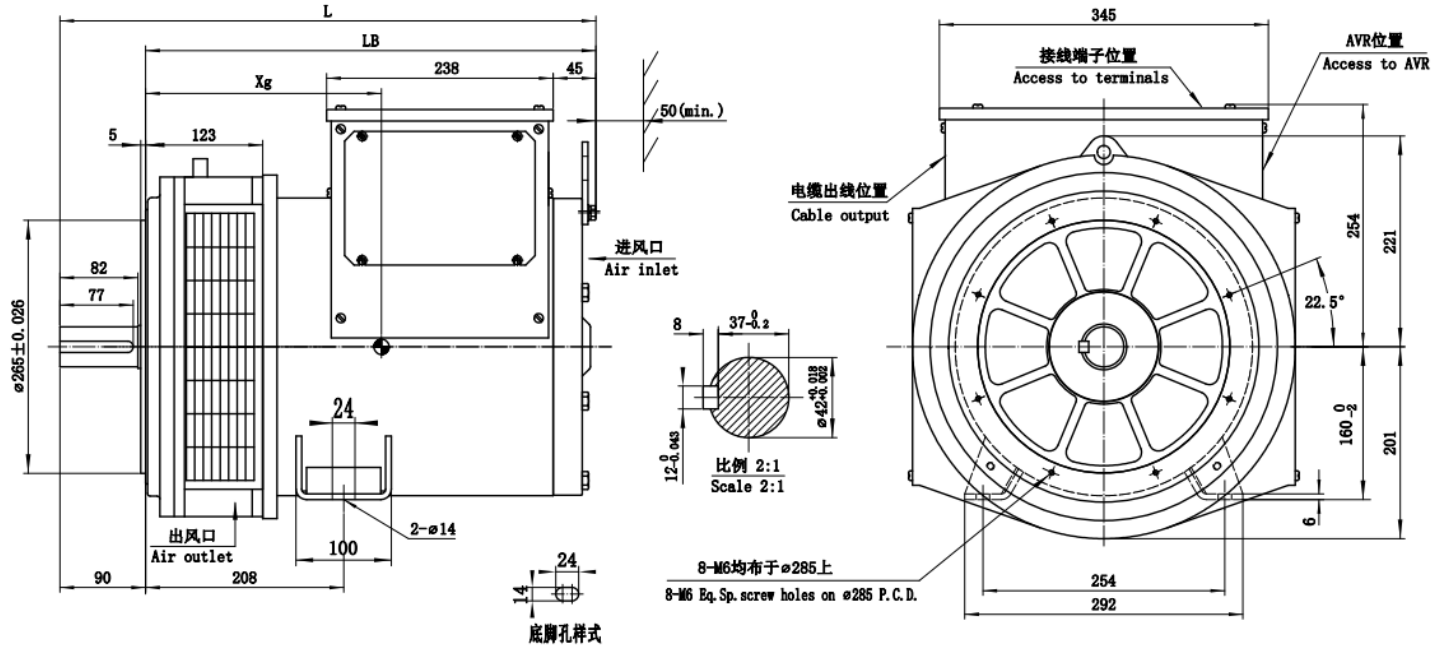

Dimensions(mm)					
Model	L	LB	*Xg	Net W.	Packing
	mm	mm	mm	kg	L x W x H(mm)
L164A65B1	517	427	183	84	634*504*572
L164A88B2	517	427	193	92	634*504*572
L164A108B3	517	427	203	103	634*504*572
L164A128C4	562	472	217	114	704*504*572
L164A14C5	562	472	225	118	704*504*572
L164A16C6	563	473	233	121	704*504*572